



Criterion™ Medium Horizontal Area Fixture 250-400 Watt

GE Lighting Systems, Inc.

Hendersonville, NC 28793-4506

READ THOROUGHLY BEFORE INSTALLING

! WARNING

Risk of electric shock

- Turn power off before servicing
- see instructions

! WARNING

Risk of fire

- Use supply wire specified on nameplate

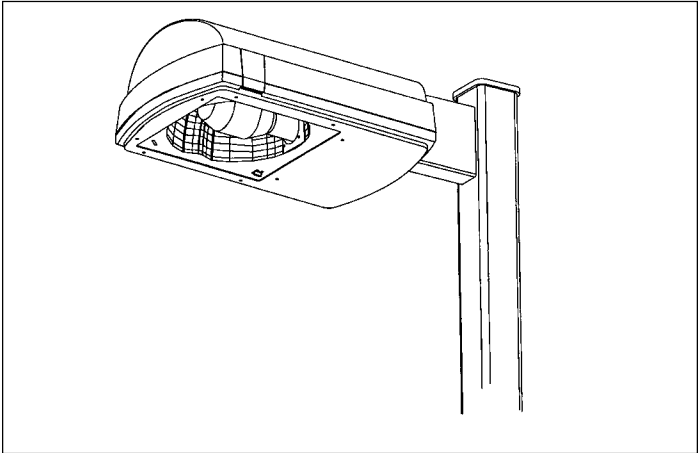

GENERAL

This luminaire is designed for outdoor lighting applications, and should not be used in areas of limited ventilation, or in high ambient temperature enclosures. For optimum performance, it should be installed and maintained according to the following recommendations.

UNPACKING

This luminaire has been properly packed so that no parts should have been damaged during transit. Inspect to confirm.

INSTALLATION

This luminaire has been configured specifically to mount to a round or square pole. To facilitate mounting, open the door by releasing the two latches and swinging the door open. The reflector may be removed by rotating the two fasteners 90 degrees and remove the reflector from the luminaire. Disconnect the socket leads to free reflector from the luminaire. SnapDrive™ may be removed for ease of installation. To remove, invert luminaire, unscrew and discard shipping screw (if so equipped), disconnect the wire harness, then depress the spring clip downward, rotate SnapDrive upward and lift off of the hinge (see Figure 1).

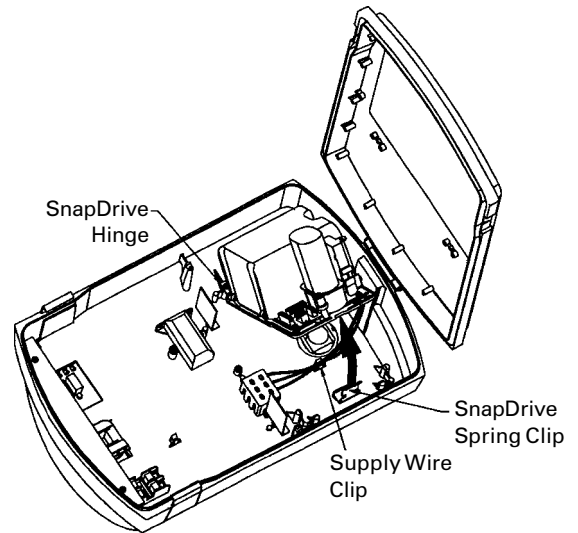

Figure 1

A. MOUNTING

! CAUTION

Unit will fall if not installed properly

- Follow installation instructions

For mounting to pre-drilled poles see Figure 2 for round poles and Figure 3 for square poles. To mount luminaire to pole:

1. Install nut plate inside the pole. Nut plate can be secured inside pole with screw provided.
2. Install two (2) studs, ensuring full penetration into nut plate.

™ Trademark of General Electric Company

These instructions do not purport to cover all details or variations in equipment nor to provide for every possible contingency to be met in connection with installation, operation or maintenance. Should further information be desired or should particular problems arise which are not covered sufficiently for the purchaser's purposes, the matter should be referred to General Electric Company.

- Align inside of mounting arm with studs and slide it into place against pole.
- Install luminaire and secure with flat washers and locknuts provided. See Figure 4.

Caution: Ensure that the nuts fully engage the two studs. Correct tightening of nuts is important to ensure proper function of mounting system. Torque nuts to 18-22 foot-pounds.

- Replace SnapDrive and reflector, reconnect socket leads and wire harness.

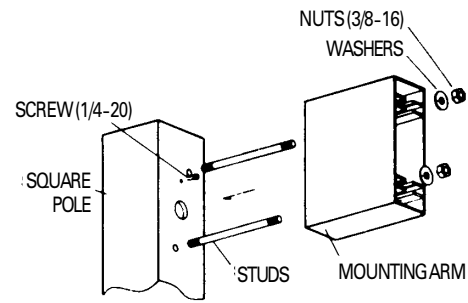

Figure 4

B. WIRING

Make all electrical connections in accordance with the National Electrical Code and any applicable local code requirements.

Verify that supply voltage is correct by comparing it to nameplate.

Route wire harness leads from luminaire through arm and into top of pole. Connect wire harness to supply wire and return to interior of pole. Replace pole cap.

Supply wiring entering from pole to interior terminal board must be routed through the wiring clips and maintain one-half inch (1/2") minimum spacing to SnapDrive (see Figure 1).

Connect ground lead to the green lead, green ground screw on housing or terminal block provided.

The SnapDrive is equipped with a **multi-volt** ballast. Ballast has been wired to the voltage indicated on the nameplate. Verify that supply voltage is correct by comparing it to nameplate. If another voltage is desired, place the voltage selection jumper onto the appropriate voltage position as indicated on the wiring diagram. Optional features such as fusing, switched quartz safety lights and photocontrols are voltage specific. **Do not change jumper positions if fixture is equipped with these features.** This will damage or destroy these optional parts and will void the UL listing of the fixture.

The SnapDrive is equipped with a **multi-watt** ballast. Ballast and jumper have been configured as indicated on the nameplate. If another wattage is desired, place the wattage selection jumper onto the appropriate position as indicated on the wiring diagram. **Do not change the wattage jumper position if fixture is equipped with fusing.** Fuses have been sized to the wattage that was ordered. Changing wattage may damage the fuses and will void the UL listing of the fixture.

Replace power fuses only with fuses of the same type and ratings.

To complete installation refer to MOUNTING.

SQUARE POLE MOUNTING: STANDARD

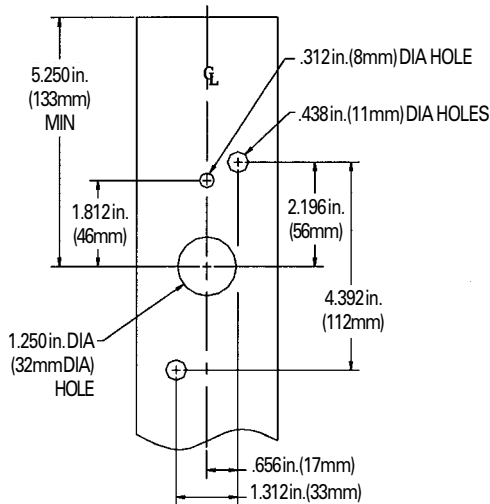

Figure 2

DRILLING TEMPLATE

ROUND POLE MOUNTING: MUST SPECIFY FOR ROUND POLE MOUNTING. ROUND POLE ADAPTER ACCESSORY AVAILABLE.

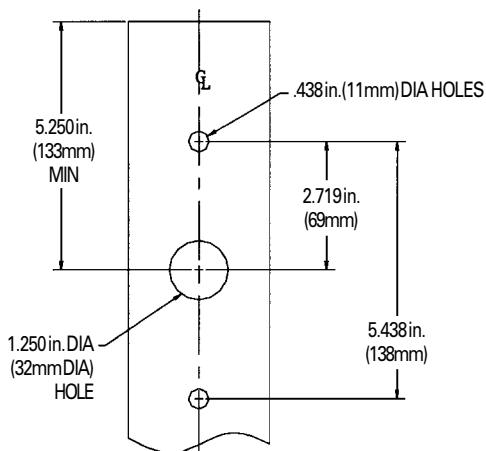
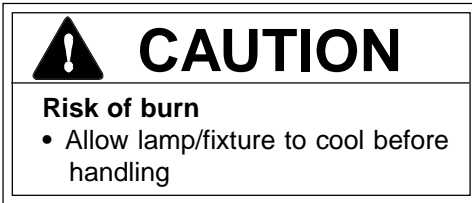

Figure 3

DRILLING TEMPLATE

LAMP INSTALLATION



Use only lamps specified on nameplate. Observe lamp manufacturer's recommendations and restrictions on lamp operation, particularly ballast type, burning position, etc. Replace blackened lamps immediately.

Lamp Tightness-Mogul Base Lamp: The lamp should be securely inserted to the NEMA-EEI specified torque of 35 inch-pounds, which is best achieved by very firm tightening sufficient to fully depress and load the center contact of the socket.

MAINTENANCE AND CLEANING

It will occasionally be necessary to clean the outside of the refractor to maintain light levels. Frequency of cleaning will depend on ambient dirt level and minimum light level which is acceptable to the user. The refractor should be washed in a solution of warm water and any mild, nonabrasive household detergent, rinsed with clean water and wiped dry. Should the optical assembly become dirty on the inside, wipe the reflector and clean the refractor in the above manner.

The light output of a luminaire is also dependent on the age of the lamp. In applications where the light level is critical, it may be desirable to replace lamps before they burn out. The lamp manufacturer can provide data showing how the lamp light output decreases with use.

GE Lighting Systems, Inc.
3010 Spartanburg Highway
Hendersonville, NC 28793
(828) 693-2000
www.gelightingsystems.com

35-201578-3R (GELS 5/01)