

The light output of a luminaire is dependent on the age of the lamp. In applications where the light level is critical, it may be desirable to replace lamps before they burn out. The lamp manufacturer can provide data showing how the lamp light output decreases with use.

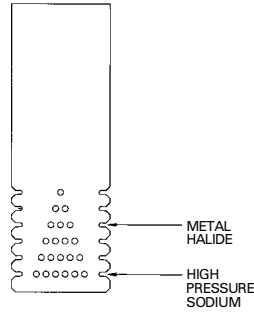

LAMP SOCKET POSITION

Figure 7

GE Lighting Systems, Inc.  
3010 Spartanburg Highway  
Hendersonville, NC 28793  
(828) 693-2000  
www.gelightingssystem.com

35-201578-2M (GELS 8/01)



GE Lighting Systems, Inc.

Hendersonville, NC 28793-4506

GEH-5837A  
**INSTRUCTIONS**  
**Criterion™ Medium Vertical Area**  
**250 - 400 Watt**

**READ THOROUGHLY BEFORE INSTALLING**

**WARNING**

**Risk of electric shock**

- Turn power off before servicing
- see instructions

**WARNING**

**Risk of fire**

- Use supply wire specified on nameplate

**GENERAL**

This luminaire is designed for outdoor lighting applications, and should not be used in areas of limited ventilation, or in high ambient temperature enclosures. Best results will be obtained if installed and maintained according to the following recommendations.

**UNPACKING**

This luminaire has been properly packed so that no parts should have been damaged during transit. Inspect to confirm. Do not set unpacked unit on glass lens.

**INSTALLATION**

Follow installation instructions:

Reflector Rotation: **Reflectors may be rotated such that reflector is in any of four positions. This allows for variations in beam aiming. In order to rotate the reflector, the following procedure should be followed.**

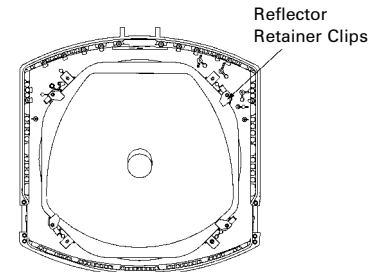

Top View of Housing with Cover removed

Figure 1

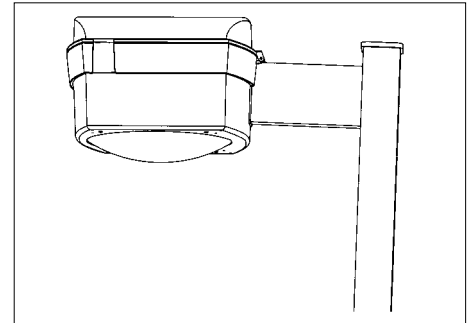

1. Open the fixture cover and lock brace.
2. Remove socket holder from reflector noting socket position. Rotate retainer clips to a position off flange of the reflector. (see figure 1)
3. Rotate reflector to desired position and rotate four retainer clips from over flange.
4. Install Socket/lamp holder to proper position (see Figure 7).
5. Close cover and latch.

**MOUNTING**

**CAUTION**

**Unit will fall if not installed properly**

- Follow installation instructions

**Note: Power leads should be pulled as mounting parts are assembled, verifying that leads are free and not pinched.**

**ARCHITECTURAL MOUNTING (ARM):**

**USE WITH SQUARE POLES PRE-DRILLED PER FIGURE 2:**

1. Install nut plate (see figure 3) **inside** pre-drilled pole. Secure nut plate to inside of pole with screw provided.
2. Install the two (2) studs ensuring that they fully penetrate the nut plate.
3. Align upper and lower guides on inside of mounting arm with their respective studs and slide it into place against pole. Arm is tapered. Make sure that the short side of arm is on top (see figure 4). Note: Wiring for unit should be pulled through arm at this time.
4. Open Luminaire cover, remove SnapDrive™ electrical system to reduce weight. (See instructions for correct SnapDrive removal.)

™ Trademark of General Electric Company

*These instructions do not purport to cover all details or variations in equipment nor to provide for every possible contingency to be met in connection with installation, operation or maintenance. Should further information be desired or should particular problems arise which are not covered sufficiently for the purchaser's purposes, the matter should be referred to General Electric Company.*

5. Install the luminaire and secure with flat washers and lock nuts provided (see figure 4). Align the system as the nuts are tightened. Spacer washers are supplied. Several washers will be needed for the top stud. (Note: Wiring for unit should be pulled through arm at this time)
6. Install SnapDrive (See below instruction)

**Caution: Ensure that nuts fully engage the two studs. Correct tightening of studs nuts is important to ensure proper function of mounting system. Torque nuts to 18-22 foot pounds (24.4 -29.8 N-m).**

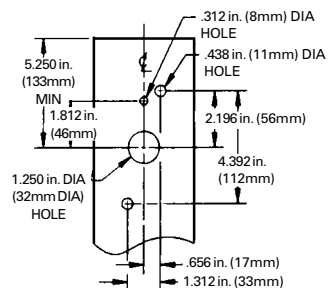

Figure 2

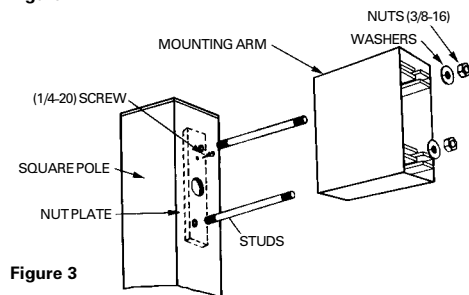

Figure 3

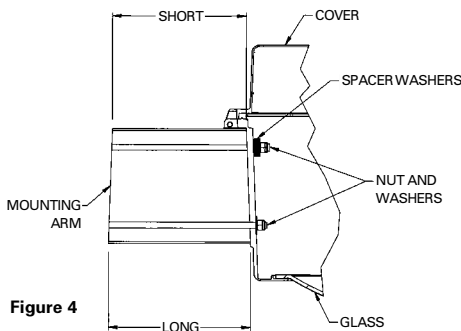
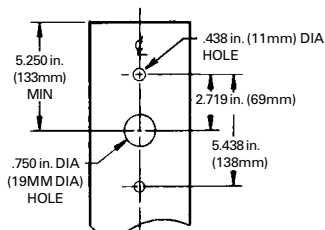

Figure 4

## OTHER MOUNTINGS

Round Pole Adapters are also available for use with housings machined with a straight hole pattern. Installation is similar to the Architectural Mounting.

Follow installation instructions



### DRILLING TEMPLATE FOR ROUND POLES



## WIRING

Make all electrical connections in accordance with all applicable code requirements (National Electrical Code, Canadian Electrical Code and applicable local Codes).

The customer must provide strain relief for the incoming power in the pole top.

1. Verify that supply voltage is correct by comparing it to nameplate.
2. Route wire harness leads from luminaire through arm and into top of pole. Connect wire harness to supply wire and return to interior pole.

Supply wiring entering from pole to interior terminal board must be routed through the wiring clips (see figure 5). Wires must not touch the reflector.

3. Connect ground lead to the green lead, green ground screw on housing or terminal block provided.
4. Install slotted grommet around supply wires for IP65 rating.

## SNAPDRIVE

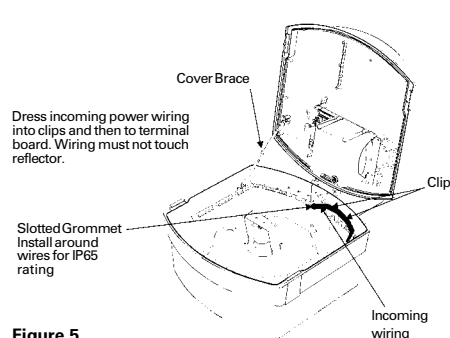

Figure 5

The SnapDrive is equipped with a multi-volt ballast. Ballast has been wired to the voltage indicated on the nameplate. If another voltage is desired, place the voltage selection jumper onto the appropriate voltage position as indicated on the wiring diagram on the SnapDrive ballast cover. Optional features such as fusing and photocontrols are voltage specific. **Do not change jumper positions if fixture is equipped with these features.** This will damage or destroy these optional parts and will void the safety listing (UL, CUL, CSA, etc.) of the fixture.

The SnapDrive is equipped with a multi-watt jumper which is configured to the wattage indicated on the nameplate. If another wattage is desired, place the wattage selection jumper onto the appropriate position as indicated on the wiring diagram on the SnapDrive ballast cover. Changing the wattage jumper will require the replacement of the lamp with the correct wattage and type lamp. **Do not change the wattage jumper position if fixture is equipped with fusing.** Fuses have been sized to the wattage that was ordered. Changing wattage may damage the fuses and will void the safety listing (UL, CUL, CSA, etc.) of the fixture.

## SNAPDRIVE REMOVAL AND INSTALLATION

**To remove Snapdrive:** with the power off, open cover by releasing the two latches. Disconnect all wire harnesses from SnapDrive. Press clip located at end of SnapDrive (see figure 6). Swing SnapDrive forward and lift off the SnapDrive retention hooks.

**To install Snapdrive:** with power off, open cover of unit. Hang module on hooks (figure 6). Swing SnapDrive into clip lifting slightly as Snapdrive is swung into place. An audible snap should be heard which indicates the module has seated. Replace wiring harnesses into proper receptacles.

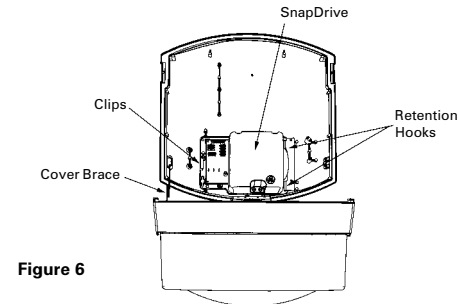
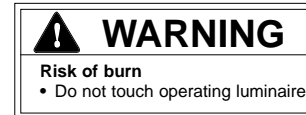
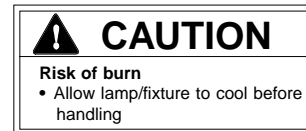

Figure 6

## LAMP INSTALLATION



Use only the type and wattage lamps specified on nameplate. (Unless wattage has been reconfigured by user.) Observe lamp manufacturer's recommendations and restrictions on lamp operation, particularly ballast type, burning position, etc.

**Lamp Tightness-Mogul Base Lamp:** The lamp should be securely inserted to the NEMA-EEI specified torque of 35 inch-pounds (3.95 N-m), which is best achieved by very firm tightening sufficient to fully depress and load the center contact of the socket.

Refer to Figure 7 for the proper lamp socket position for Metal Halide and High Pressure Sodium lamps.

## MAINTENANCE AND CLEANING

It will occasionally be necessary to clean the outside of the glass to maintain light levels. Frequency of cleaning will depend on ambient dirt level and minimum light level that is acceptable to the user. The glass should be washed in a solution of warm water and any mild, nonabrasive household detergent, rinsed with clean water and wiped dry. Should the optical assembly become dirty on the inside, wipe the reflector and clean the refractor in the above manner.